

**Features**

- Fit automatic placement equipment.
- Fit Compatible with vapor-phase reflow, Infrared reflow and wave solder processes.
- White package.
- Pb-free.
- RoHS compliant.

**Descriptions**

- For higher packing density .
- For minature applications .
- Yellow Diffusion lens .
- Chip material : InGaN .
- Emitting color : White .

**Package Outline Dimensions**

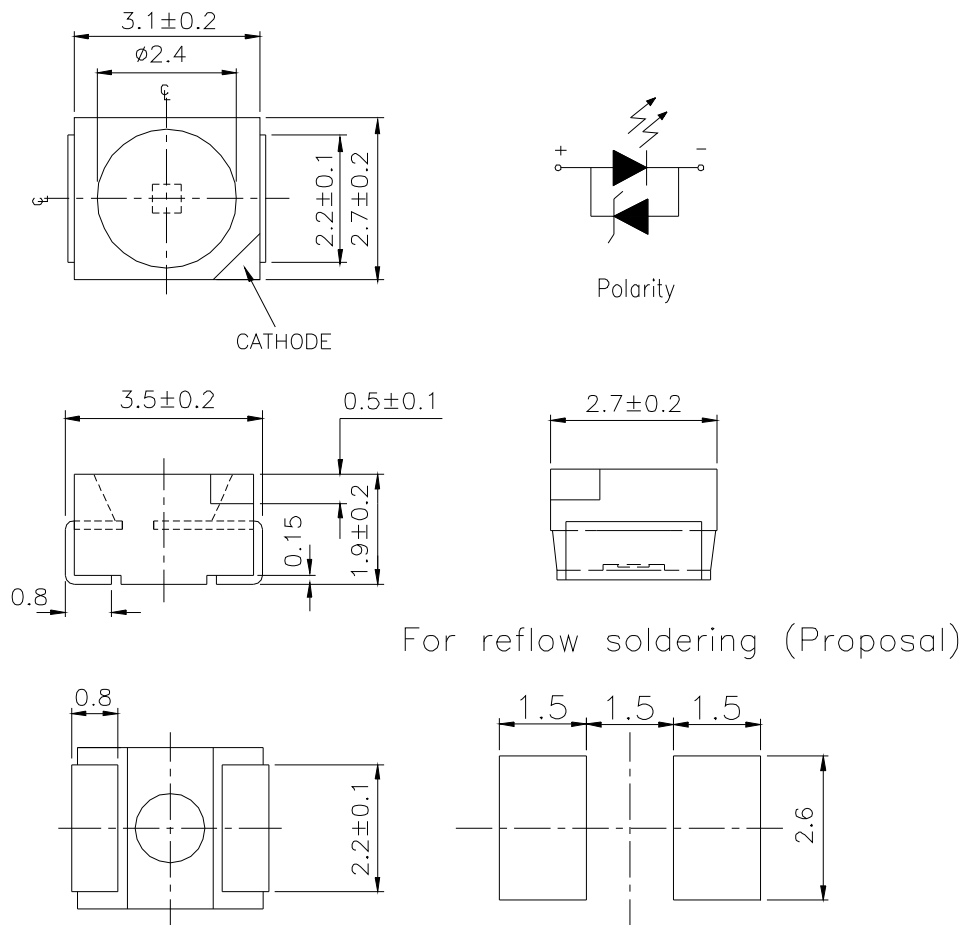

For reflow soldering (Proposal)

**Note:** The tolerances unless mentioned is  $\pm 0.1$ mm ,Unit = mm

### Absolute Maximum Ratings (Ta=25°C)

Parameter	Symbol	Rating	Unit
Reverse Voltage	V <sub>R</sub>	5	V
Forward Current	I <sub>F</sub>	25	mA
Operating Temperature	T <sub>opr</sub>	-40 ~ +85	°C
Storage Temperature	T <sub>stg</sub>	-40 ~ +90	°C
Electrostatic Discharge(HBM)	ESD	2000	V
Power Dissipation	P <sub>d</sub>	110	mW
Peak Forward Current (Duty 1/10 @1KHz)	I <sub>FP</sub>	100	mA
Soldering Temperature	T <sub>sol</sub>	Reflow Soldering : 260 °C for 10 sec. Hand Soldering : 350 °C for 3 sec.	

### Electro-Optical Characteristics (Ta=25°C)

Parameter	Symbol	Min.	Typ.	Max.	Units	Condition
Luminous Intensity	I <sub>V</sub>	715	-----	1800	mcd	I <sub>F</sub> =20mA
Forward Voltage	V <sub>F</sub>	2.70	-----	3.50	V	I <sub>F</sub> =20mA
Viewing Angle	2 θ 1/2	--	120	--	deg	I <sub>F</sub> =20mA

Notes:

- 1.Tolerance of Luminous Intensity ±10%
- 2.Tolerance of Forward Voltage ±0.1V

### Bin Range Of Luminous Intensity

Bin Code	Min.	Max.	Unit	Condition
V1	715	900	mcd	I <sub>F</sub> =20mA
V2	900	1120		
W1	1120	1420		
W2	1420	1800		

### Bin Range Of Forward Voltage

Group	Bin Code	Min.	Max.	Unit	Condition
F	10	2.70	2.90	V	I <sub>F</sub> =20mA
	11	2.90	3.10		
	12	3.10	3.30		
	13	3.30	3.50		

Specific binning requirements- please contact our home office

Notes:

1. Tolerance of Luminous Intensity  $\pm 10\%$
2. Tolerance of Forward Voltage  $\pm 0.1V$

Group	Bin Code	CIE_x	CIE_y	Bin Code	CIE_x	CIE_y
<b>F</b>	<b>B3</b>	0.287	0.295	<b>B4</b>	0.307	0.315
		0.283	0.305		0.304	0.33
		0.304	0.330		0.33	0.36
		0.307	0.315		0.33	0.339
	<b>B5</b>	0.296	0.276	<b>B6</b>	0.311	0.294
		0.287	0.295		0.307	0.315
		0.307	0.315		0.330	0.339
		0.311	0.294		0.330	0.318

\*The C.I.E. 1931 chromaticity diagram ( Tolerance  $\pm 0.01$ ).

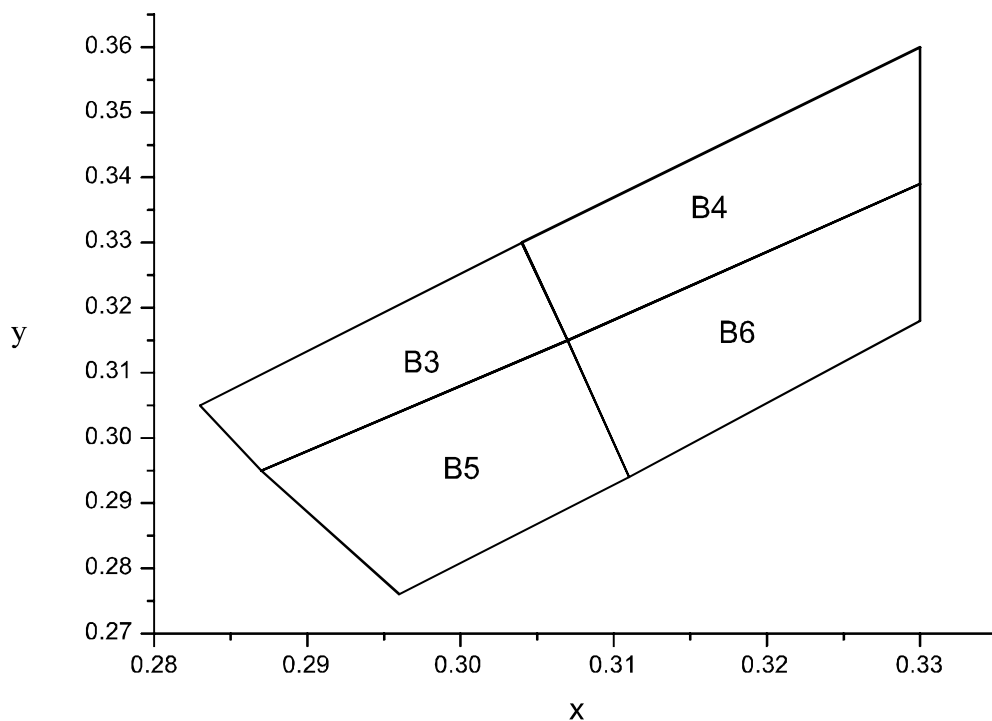

## Typical Electro-Optical Characteristics Curves

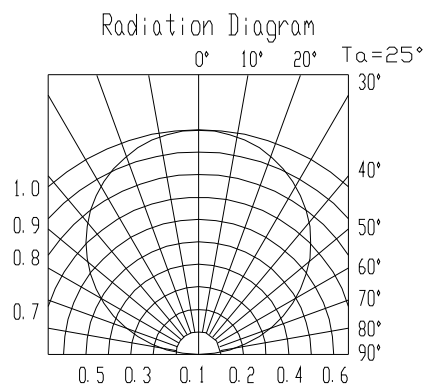
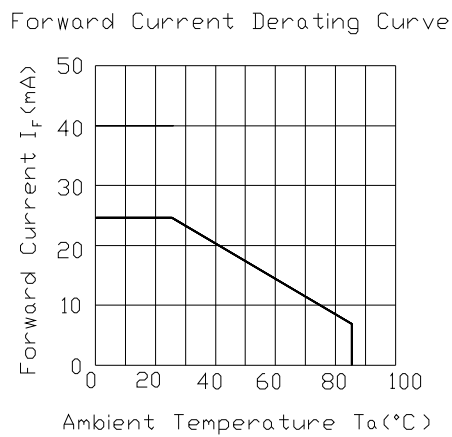
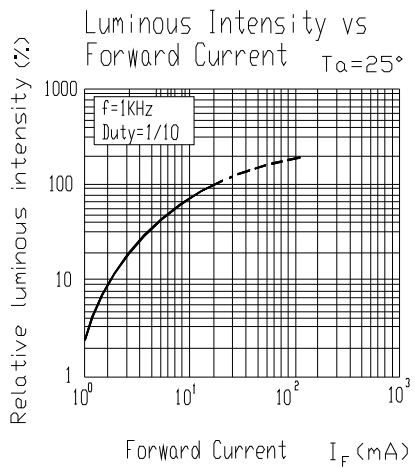
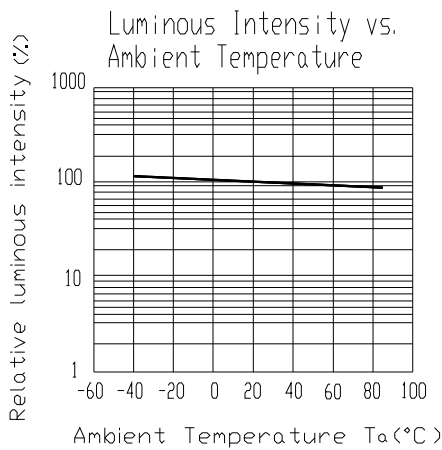
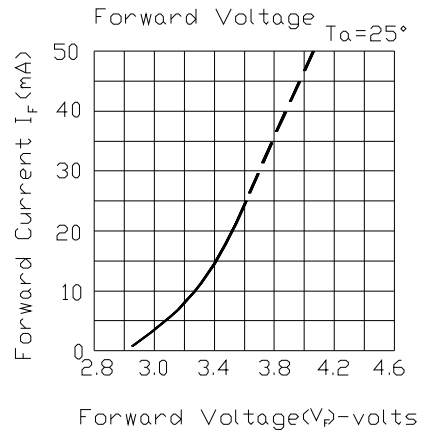
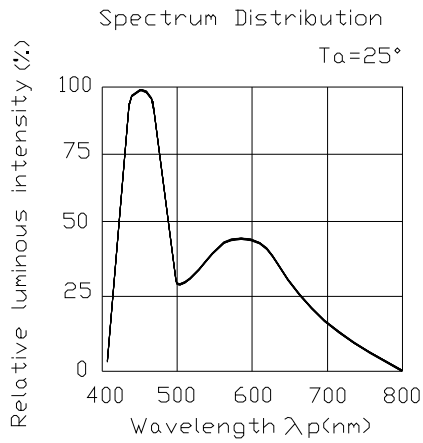

## Reel Dimensions

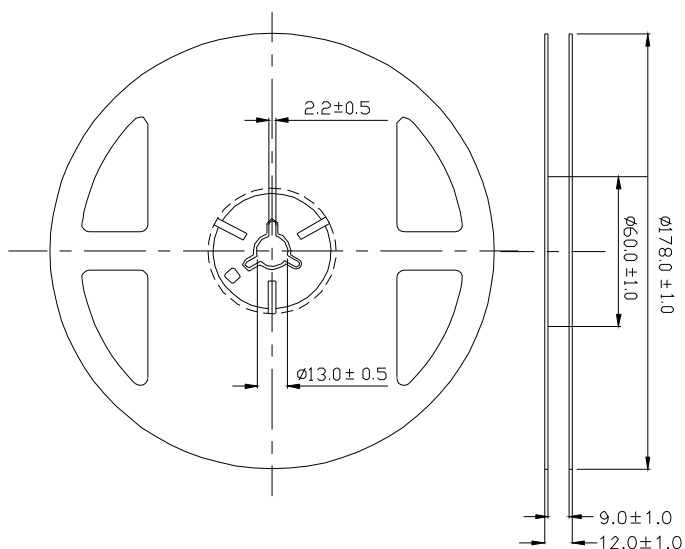

**Note:** The tolerances unless mentioned is  $\pm 0.1$ mm ,Unit = mm

**Carrier Tape Dimensions: Loaded quantity 2000 PCS per reel.**

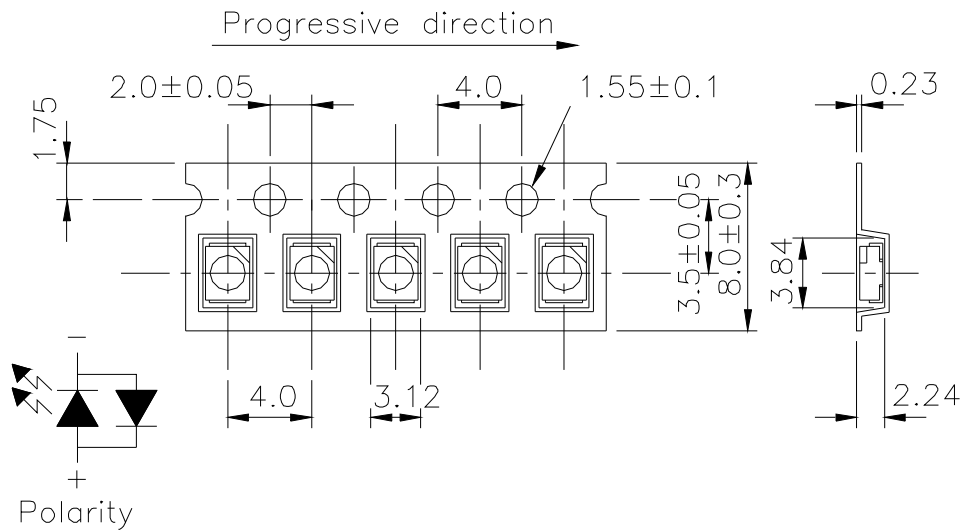

**Note:** The tolerances unless mentioned is  $\pm 0.1$ mm ,Unit = mm

**Moisture Resistant Packaging**

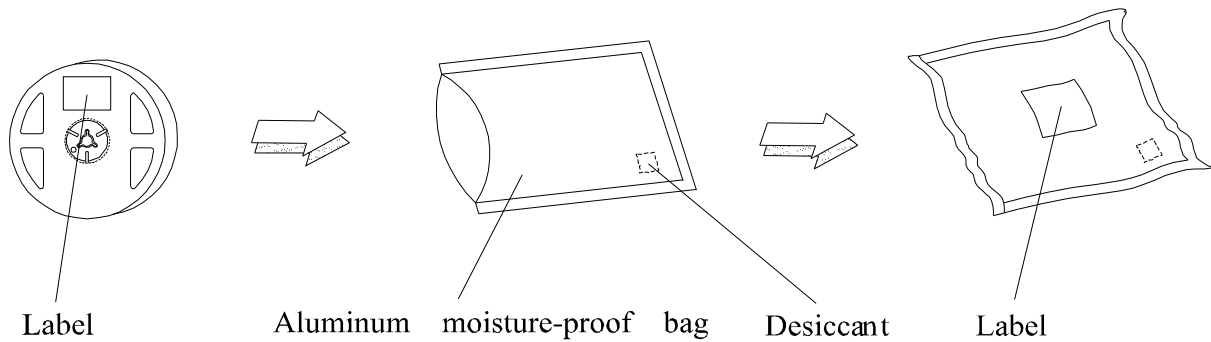

**67-11/W1C-FV1W2F/2T**

Soldering Condition

1. Pb-free solder temperature profile

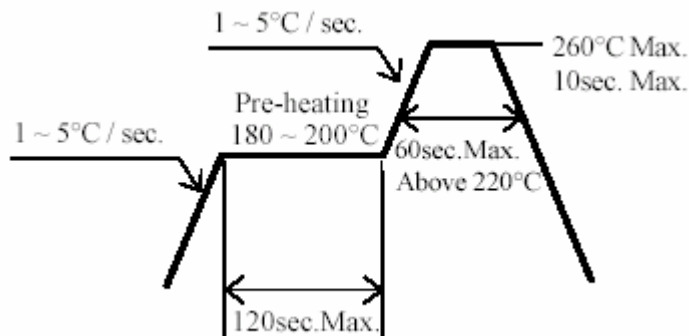

- 2. Reflow soldering should not be done more than two times.
- 3 When soldering, do not put stress on the LEDs during heating.
- 4 After soldering, do not warp the circuit board.

Soldering Iron

Each terminal is to go to the tip of soldering iron temperature less than 350°C for 3 seconds within once in less than the soldering iron capacity 25W. Leave two seconds and more intervals, and do soldering of each terminal. Be careful because the damage of the product is often started at the time of the hand solder.

