

11

DO NOT SCALE THIS DRAWING

REVISIONS				
SYM	DESCRIPTION	DATE	E.C.O. NO.	APPR.
A	OFFICIAL ENG. RELEASE TO MFG.	12/12/88	35-43	DR

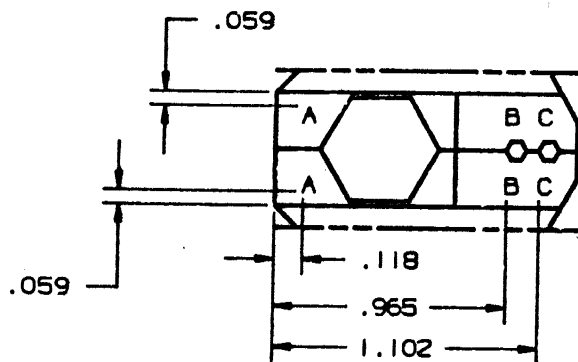

DIES ALIKE IF NOT OTHERWISE STATED. MARKING ALIGNED WITH CAVITIES STAMPED LETTERS A, B & C. TEXT HEIGHT 1/16.

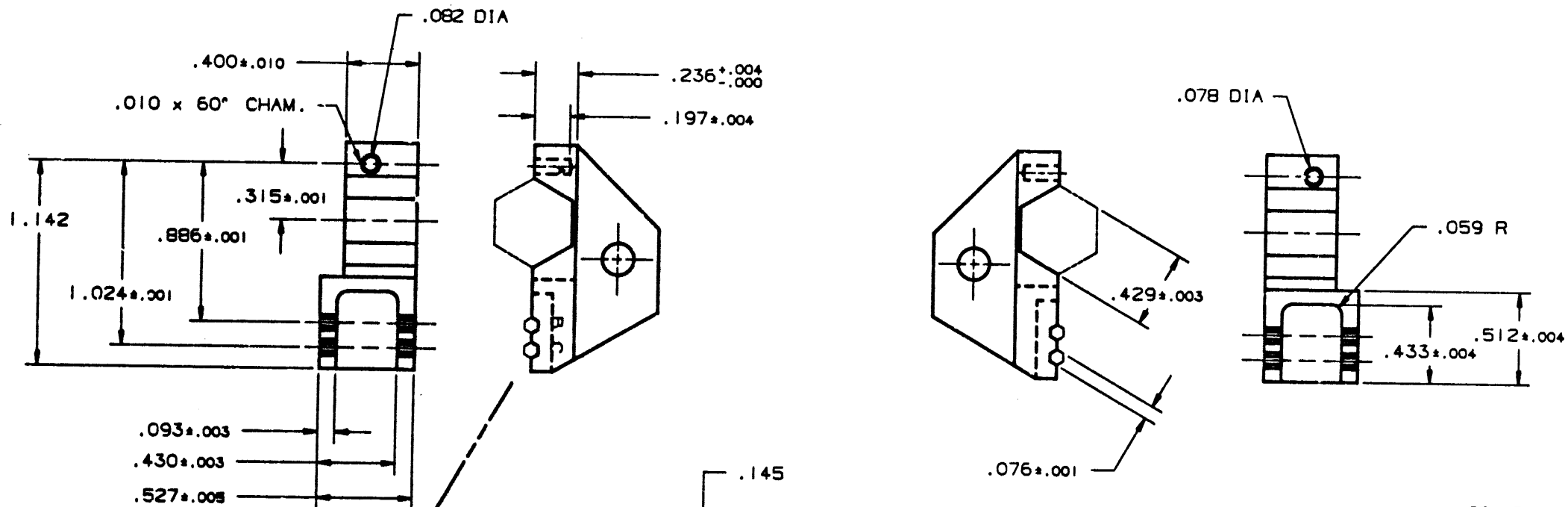

227-1417  
DRAWING NUMBER ISSUE  
A

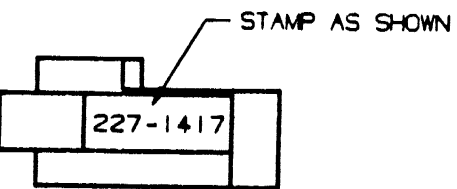

- NOTES:
1. MATERIAL: CRIMPING DIES - TOOL STEEL. HEAT TREAT TO ROCKWELL C52-60
  2. FINISH: FINISH ON CRIMPING SURFACES 32 MICROINCHES MAX. BLACK OXIDE COATING PER MIL-C-13924.
  3. USE WITH 227-987 HANDLE.
  4. USE TO CRIMP 82-5589CC TWIN PLUG.

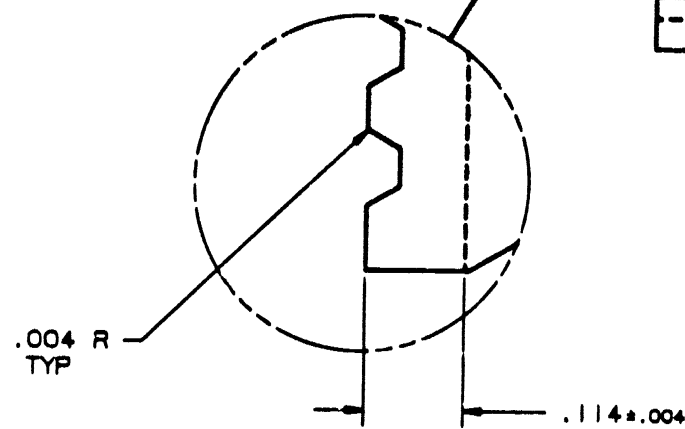

PART NO.	QUAN	UOM	DATE	DESCRIPTION	CODE	FINISH
LIST OF MATERIAL						

REMOVE ALL BURRS, BREAK CORNERS AND SHARP EDGES 90° MAXIMUM UNLESS OTHERWISE SPECIFIED.

NOTICE - These drawings, specifications or other data (1) are, and remain the property of Amphenol Corp. (2) must be returned upon request; and (3) are confidential and are not to be disclosed to any person other than those to whom they are given by Amphenol Corp. The furnishing of these drawings, specifications, or other data by Amphenol Corp. or by any other person to anyone for any purpose is not to be regarded by implication or otherwise as in any manner (a) granting rights or permitting such holder or any other person to manufacture, use or sell any product, process or design, patented or otherwise, that may in any way be related to or disclosed by said drawings, specifications or other data.

NEXT ASSY	USE' ON	UNLESS OTHERWISE SPECIFIED DIMENSIONS ARE IN INCHES. TOLERANCES NOT OTHERWISE SPECIFIED ARE:	DRAWN BY	DATE	TITLE
NOTE 1		2 PLACE DECIMAL ± .015 (0.381 mm)	TERRI ALBERA	11-2-88	DIE SET
NOTE 2		3 PLACE DECIMAL ± .005 (0.127 mm)	DATE	12-9-88	
FINISH		REFERENCE DRAWING NO.	ENGINEER	DATE	
		EAR 70264-2	DATE	12-2-88	
		PRESSMASTER	QUANTITY ASSURANCE	DATE	
		4100-2054	DATE	12-14-88	

SCALE	SHEET	OF	ISSUE
2:1			A

CODE IDENTIFICATION	DRAWING SIZE	DRAWING NO.
74868	C	227-1417

11

58

8.5"

11"

11

11

58

8.5"

11"